

Installation Instructions:

Kit #: 7-242

FRONT CONTROL ARM KIT

MODEL: TRAILBLAZER YEAR: 2006-2009



1-888-PROTHANE
3580 Cadillac Ave, Costa Mesa, CA 92626

PARTS LIST:

19-1750-001	GREASE	6 EA
SLV-60529	7/8X.156X1.800 (DOM)	4 EA
SLV-60679	1.0X.219X2.480" GOLD ZINC	2 EA
SLV-60944	1.0X.219X2.450" GOLD ZINC	2 EA
U-64468	LWR C/A BUSH FRON	2 EA
U-64469	LWR C/A BUSH REAR	2 EA
U-64470	UPPER C/ARM BUSHING	4 EA
WASH-70	9/16"X1.750X0.125 FLAT WASH GLD	4 EA

NOTES:

Please refer to a factory service manual before any disassembly or reassembly of your vehicle for proper instructions. Check service manual to ensure proper torque specs during installation.

Prothane bushings generally do NOT meet in the center. The "crush" or amount the bolt can be tightened is determined by the length of the sleeve.
For all articulating bushings, make sure to apply SUPER GREASE (supplied) to ALL SURFACES for the bushing that contacts metal.
For all stationary bushings we recommend applying a light coat of lithium or teflon grease (not supplied) to OD and ID of bushings to aid installation.
REUSE all factory hardware unless replacement pieces are supplied

*Prothane Motion Control highly recommends that all of our polyurethane suspension kits be installed by a qualified technician.**

Removal Procedure Upper Control Arms

- Raise and support the vehicle.
- Remove the tire and wheel.
- Remove and discard the upper ball joint to upper control arm pinch bolt and nut.
- Disconnect the upper control arm from the steering knuckle.
- Disconnect the ABS wheel speed sensor wiring harness from the upper control arm.
- When doing the passenger side, remove the battery tray.
- Gently pry out on the inner fender body panel to access forward facing bolt.
- Remove the upper control arm mounting bolts.
- Remove the upper control arm.

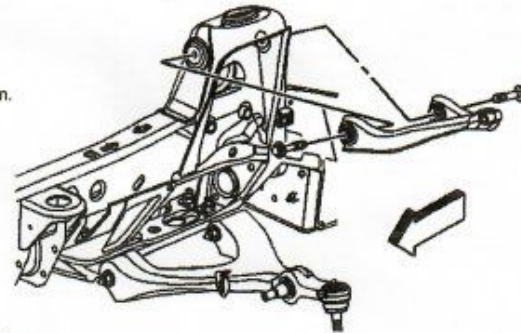

Installation of Bushings

- You must burn out all the bushings on the upper control arms, you will reuse all the outer shells.
- The upper will get the Washers Supplied between bolt and bushing
- Grease all bushings that touch metal for assembly.

Installation Procedure Upper Control Arms

- Install the upper control arm.
- Gently pry out on the inner fender body panel to access forward facing bolt.
- Install the upper control arm mounting bolt. (torque 111lb ft)
- Install the battery tray if removed
- Connect the ABS wheel speed sensor wiring harness to the upper control arm.
- Connect the upper control arm to the steering knuckle.
- Install the tire and wheel.
- Lower vehicle.
- Get alignment done..



Removal Procedure Lower Control Arms

- Disconnect the outer tie rod from the steering knuckle.
- Remove the stabilizer shaft link lower retaining nut.
- Disconnect the stabilizer shaft link and washer from the lower control arm.
- Remove the shock module yoke lower mounting nut.
- Disconnect the shock module yoke from the lower control arm.
- Disconnect the lower ball joint from the steering knuckle.
- Remove the lower control arm to lower control arm bracket.
- IMPORTANT: Note the direction the bolts are removed.
- Remove the lower control arm to lower control arm bracket mounting bolts.
- IMPORTANT: Take care not to disengage the Axle shaft (4WD Only)
- Pivot the lower control arm outward and downward in order to disconnect the lower control arm from the lower control arm bracket.
- IMPORTANT: Ensure that the spacer stays in position on the front control arm bracket front bushing.
- Remove the lower control arm from the vehicle

Installation of Bushings

- You will press out the old bushings and install the new bushings
- Grease all bushings that touch metal for assembly.

Installation Procedure Lower Control Arms

- Position the lower control arm ball joint stud to the steering knuckle.
- IMPORTANT: Ensure that the spacer stays in position on the front control arm bracket front bushing.
- Pivot the lower control arm outward and upward in order to connect the lower control arm to the lower control arm bracket.
- Install the lower control arm to lower control arm bracket mounting bolts.
- Install the lower control arm to lower control arm bracket mounting nuts.
- Torque Spec. 96 lb ft
- Connect the shock module yoke to the lower control arm.
- Torque Spec. 81 lb ft
- Install a new lower ball joint retaining nut
- Torque Spec. 81 lb ft
- IMPORTANT: There is a washer between the stabilizer shaft link and the lower control arm made of hardened steel and has a felt inner liner. Only replace this washer with an identical washer. Standard washer will fail.

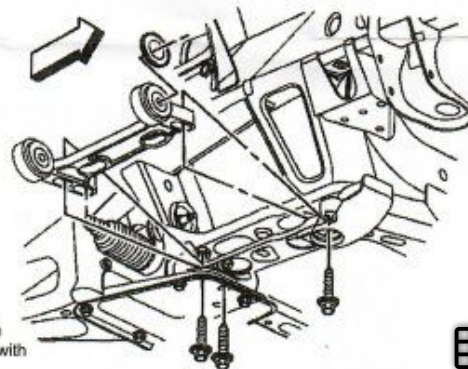

Installation Instructions:

Kit #: 7-242

FRONT CONTROL ARM KIT

MODEL: TRAILBLAZER YEAR: 2006-2009



1-888-PROTHANE
3580 Cadillac Ave, Costa Mesa, CA 92626

PARTS LIST:

19-1750-001	GREASE	6 EA
SLV-60529	7/8X.156X1.800 (DOM)	4 EA
SLV-60679	1.0X.219X2.480" GOLD ZINC	2 EA
SLV-60944	1.0X.219X2.450" GOLD ZINC	2 EA
U-64468	LWR C/A BUSH FRON	2 EA
U-64469	LWR C/A BUSH REAR	2 EA
U-64470	UPPER C/ARM BUSHING	4 EA
WASH-70	9/16"X1.750X0.125 FLAT WASH GLD	4 EA



NOTES:

Please refer to a factory service manual before any disassembly or reassembly of your vehicle for proper instructions. Check service manual to ensure proper torque specs during installation.

Prothane bushings generally do NOT meet in the center. The "crush" or amount the bolt can be tightened is determined by the length of the sleeve.
For all articulating bushings, make sure to apply SUPER GREASE (supplied) to ALL SURFACES for the bushing that contacts metal.
For all stationary bushings we recommend applying a light coat of lithium or teflon grease (not supplied) to OD and ID of bushings to aid installation.
REUSE all factory hardware unless replacement pieces are supplied

Prothane Motion Control highly recommends that all of our polyurethane suspension kits be installed by a qualified technician.

Removal Procedure Upper Control Arms

- Raise and support the vehicle.
- Remove the tire and wheel.
- Remove and discard the upper ball joint to upper control arm pinch bolt and nut.
- Disconnect the upper control arm from the steering knuckle.
- Disconnect the ABS wheel speed sensor wiring harness from the upper control arm.
- When doing the passenger side, remove the battery tray.
- Gently pry out on the inner fender body panel to access forward facing bolt.
- Remove the upper control arm mounting bolts.
- Remove the upper control arm.

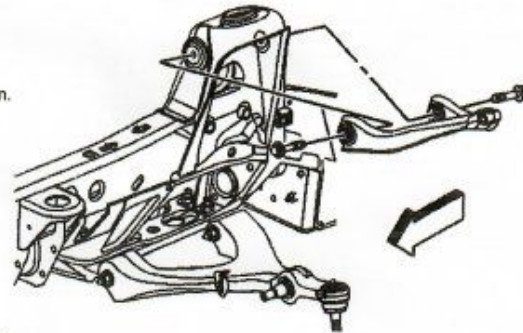

Installation of Bushings

- You must burn out all the bushings on the upper control arms, you will reuse all the outer shells.
- The upper will get the Washers Supplied between bolt and bushing
- Grease all bushings that touch metal for assembly.

Installation Procedure Upper Control Arms

- Install the upper control arm.
- Gently pry out on the inner fender body panel to access forward facing bolt.
- Install the upper control arm mounting bolt. (torque 111lb ft)
- Install the battery tray if removed
- Connect the ABS wheel speed sensor wiring harness to the upper control arm.
- Connect the upper control arm to the steering knuckle.
- Install the tire and wheel.
- Lower vehicle.
- Get alignment done..



Removal Procedure Lower Control Arms

- Disconnect the outer tie rod from the steering knuckle.
- Remove the stabilizer shaft link lower retaining nut.
- Disconnect the stabilizer shaft link and washer from the lower control arm.
- Remove the shock module yoke lower mounting nut.
- Disconnect the shock module yoke from the lower control arm.
- Disconnect the lower ball joint from the steering knuckle.
- Remove the lower control arm to lower control arm bracket.
- IMPORTANT: Note the direction the bolts are removed.
- Remove the lower control arm to lower control arm bracket mounting bolts.
- IMPORTANT: Take care not to disengage the Axle shaft (4WD Only)
- Pivot the lower control arm outward and downward in order to disconnect the lower control arm from the lower control arm bracket.
- IMPORTANT: Ensure that the spacer stays in position on the front control arm bracket front bushing.
- Remove the lower control arm from the vehicle

Installation of Bushings

- You will press out the old bushings and install the new bushings
- Grease all bushings that touch metal for assembly.

Installation Procedure Lower Control Arms

- Position the lower control arm ball joint stud to the steering knuckle.
- IMPORTANT: Ensure that the spacer stays in position on the front control arm bracket front bushing.
- Pivot the lower control arm outward and upward in order to connect the lower control arm to the lower control arm bracket.
- Install the lower control arm to lower control arm bracket mounting bolts.
- Install the lower control arm to lower control arm bracket mounting nuts.
- Torque Spec. 96 lb ft
- Connect the shock module yoke to the lower control arm.
- Torque Spec. 81 lb ft
- Install a new lower ball joint retaining nut
- Torque Spec. 81 lb ft
- IMPORTANT: There is a washer between the stabilizer shaft link and the lower control arm made of hardened steel and has a felt inner liner. Only replace this washer with an identical washer. Standard washer will fail.

